

MODELS MODELLI
SRC-F-185 - SRC-F-222

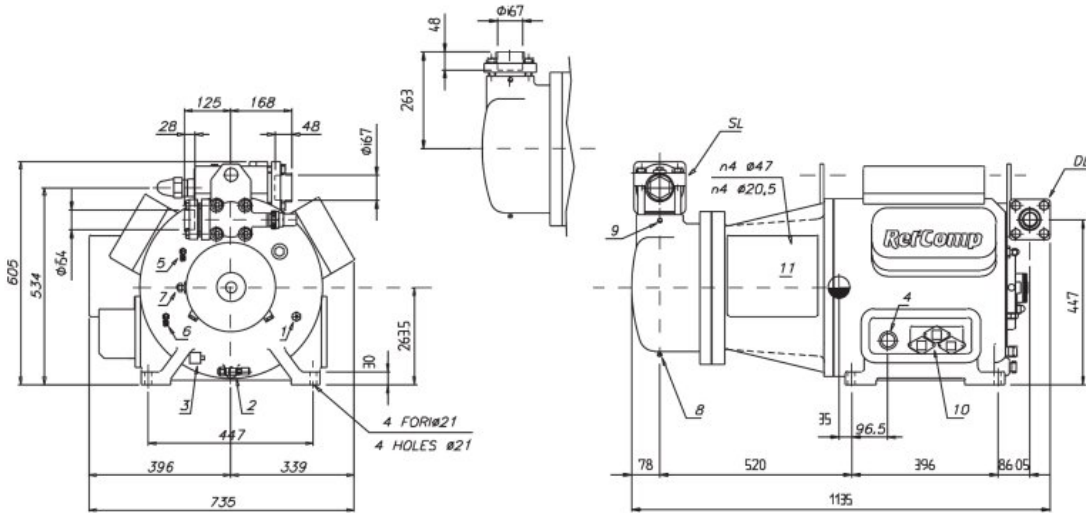

MODELS MODELLI
SRC-F-258 - SRC-F-295

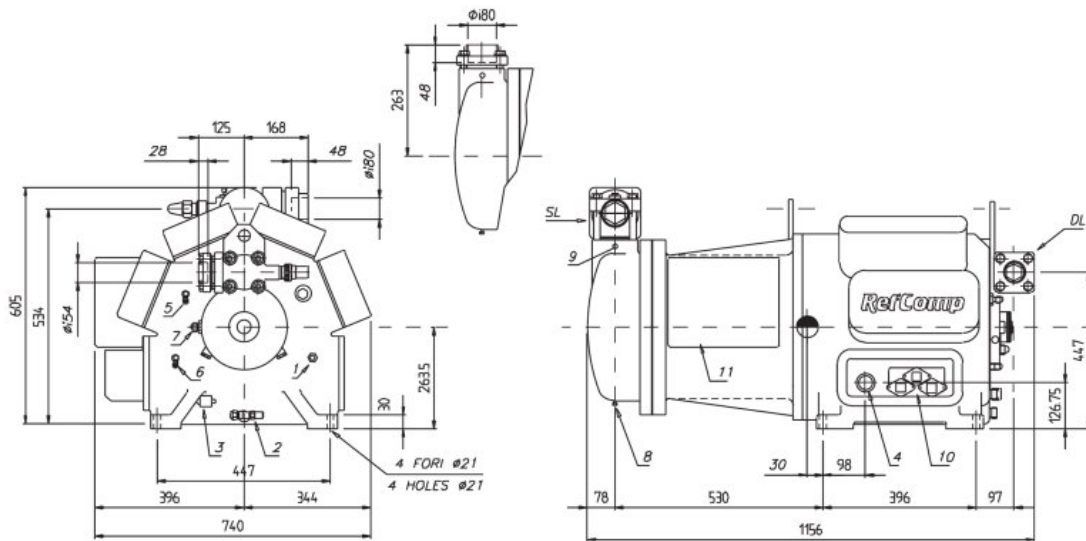

KEY

- 1) Oil charging 3/4" NPT
- 2) Oil drain 3/8" S.A.E. - FLARE
- 3) Crankcase heater 1/2" NPT
- 4) Oil level sight glass
- 5) High pressure 1/4" S.A.E. - FLARE
- 6) Low pressure 1/4" S.A.E. - FLARE
- 7) Oil pressure 1/4" S.A.E. - FLARE
- 8) End cover oil drain 1/4" NPT
- 9) Low pressure 1/8" NPT
- 10) Solenoid valves
- 11) Terminal box
- DL) Discharge shut off valve
- SL) Suction shut off valve

LEGENDA

- 1) Tappo carica olio 3/4" NPT
- 2) Scarico olio 3/8" S.A.E. - FLARE
- 3) Resistenza carter 1/2" NPT
- 4) Spia olio
- 5) Alta pressione 1/4" S.A.E. - FLARE
- 6) Bassa pressione 1/4" S.A.E. - FLARE
- 7) Pressione olio 1/4" S.A.E. - FLARE
- 8) Coperchio scarico olio 1/4" NPT
- 9) Bassa pressione 1/8" NPT
- 10) Valvole solenoidi
- 11) Scatola connessioni elettriche
- DL) Rubinetto di scarico
- SL) Rubinetto di aspirazione